



***iprotect***<sup>®</sup>  
**Together we can protect**

Hydraulic Filter Division Europe

aerospace  
climate control  
electromechanical  
**filtration**  
fluid & gas handling  
hydraulics  
pneumatics  
process control  
sealing & shielding



ENGINEERING YOUR SUCCESS.

Filtration directly influences equipment productivity and profitability. Parker *i*protect<sup>®</sup> products enable machine owners and OEM's to gain maximum performance from their hydraulic equipment.

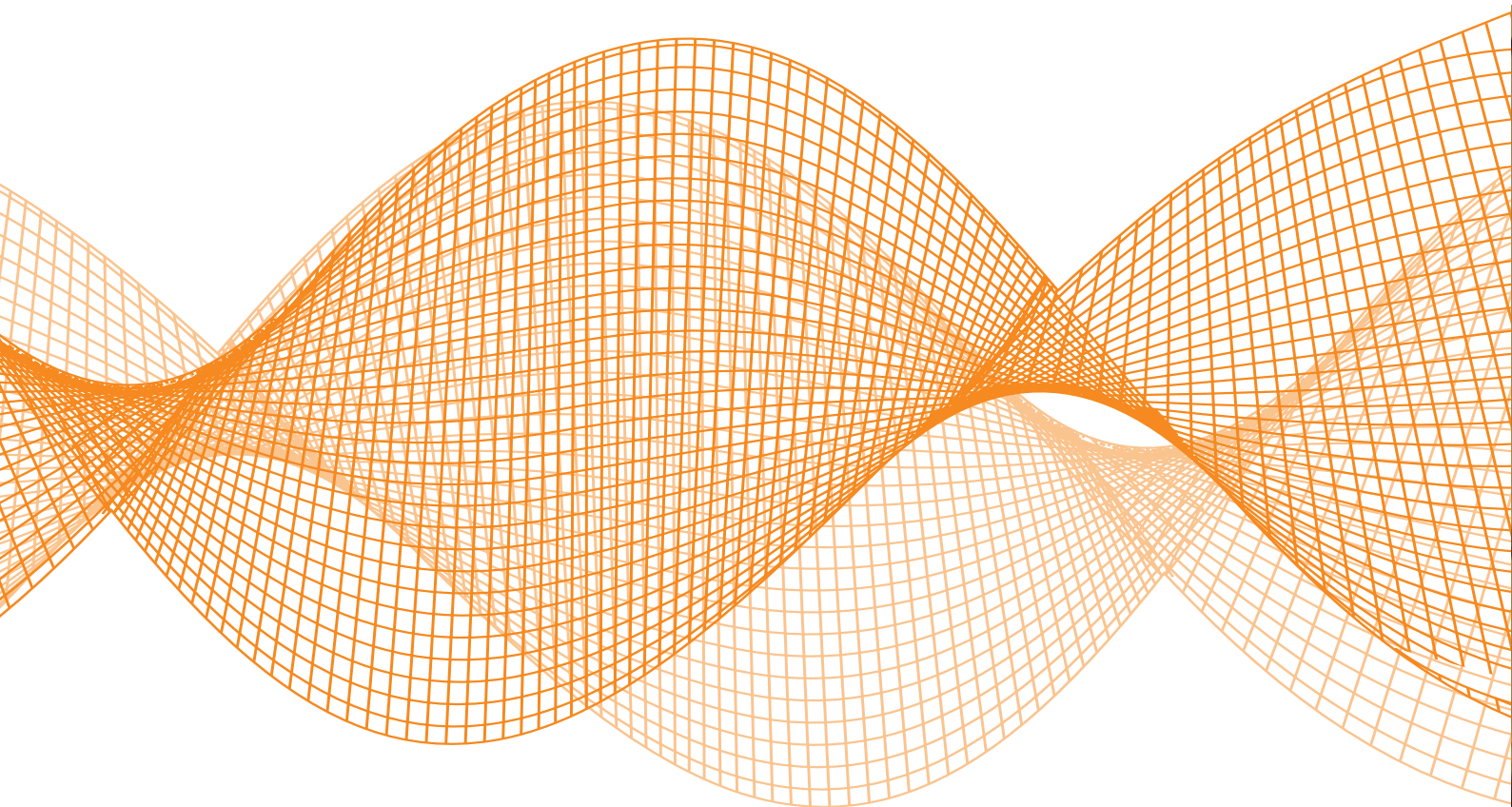

# Introducing *iprotect*<sup>®</sup>

Parker has recognized the market need to provide more compact filter solutions. The EPF *iprotect*<sup>®</sup> range is designed to offer high quality filtration of hydraulic systems, breaking new ground to reduce the cost of ownership by improving system productivity and profitability.

A radical, innovative approach is applied with the design of the *iprotect*<sup>®</sup> product family, a new patented filter element allowing easy integration of high pressure filtration in systems.

A unique feature is that the filter elements remain inside the filter bowl when changing the filter element. This can save over 500 mm of space envelope compared with traditional high pressure

filters.

The patented element design helps to guarantee the quality of filtration, which directly impacts system safety, productivity and profitability.

- Guaranteed quality of filtration.
- More compact solutions are possible.
- The filter element remains in the filter bowl.
- Reusable bypass and element core, both integral

part of the filter bowl.

- Reduces waste typically by over 50%.
- No risk of mistakes during change of filter elements due to product design.
- Unique OEM branding opportunities.
- Easy to integrate into hydraulic manifold solutions.

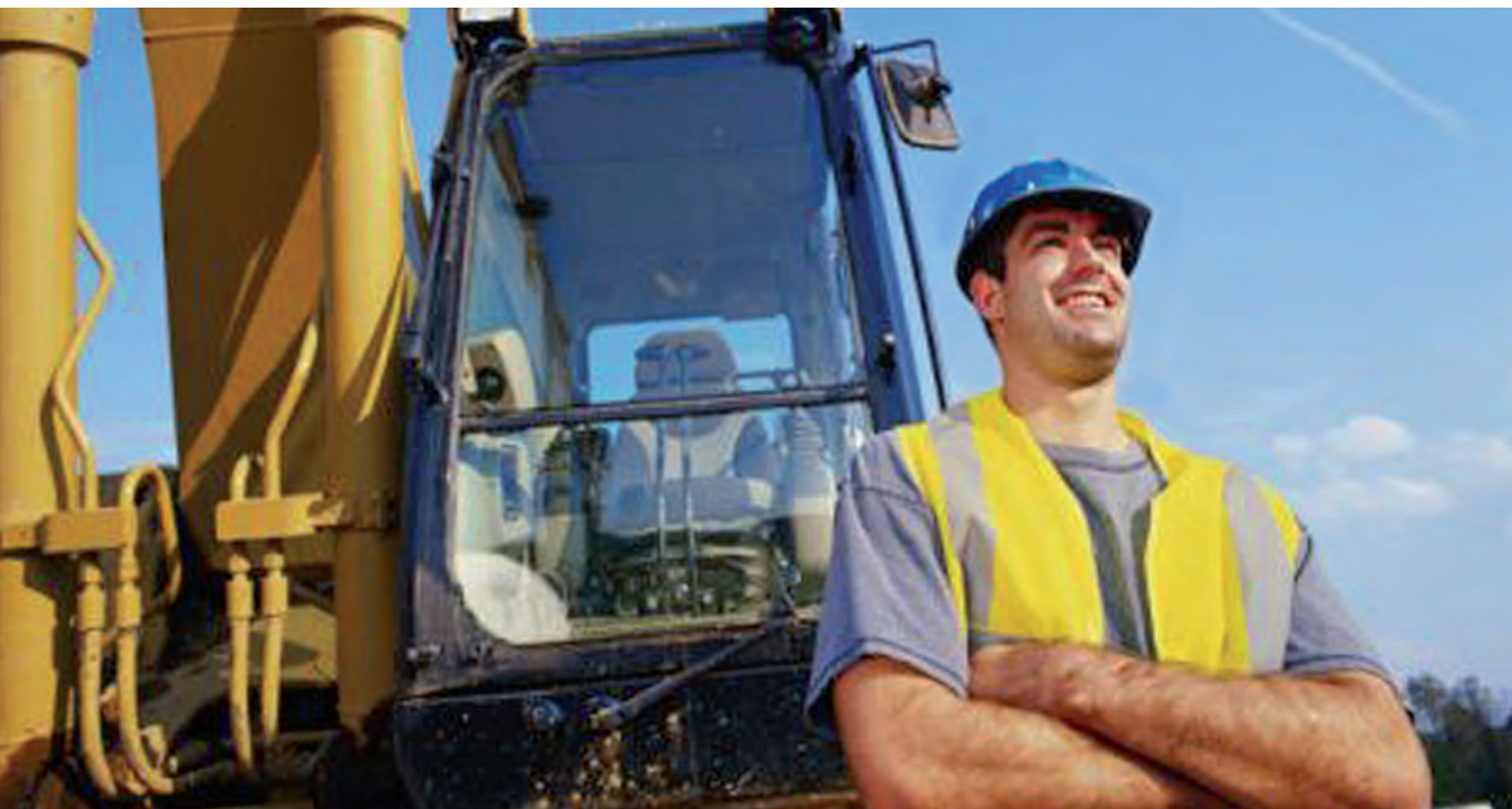

A full-page background image showing an industrial setting. In the foreground, a worker wearing a hard hat and safety gear is seated inside a yellow safety cage or lift. The cage is part of a larger yellow structure. In the background, there are tall industrial towers, a crane, and other complex machinery under a clear blue sky. The overall scene is brightly lit, suggesting a sunny day.

# SAFETY

Parker is proud to demonstrate their responsibility towards the industry by offering products that improve the integral safety of systems. The EPF *iprotect*<sup>®</sup> product line contributes to the design of dedicated system circuits with a guaranteed quality of filtration.



## ***iprotect***<sup>®</sup> **Your safety**

### Safety is imbedded our product design

- Guaranteed quality of filtration improves the integral safety of equipment.
- *iprotect*<sup>®</sup> filters are ATEX classified.
- Integrated solutions to minimize potential leakage points
- High filter media efficiency to provide maximum protection to critical systems.
- Optional integrated Condition Monitoring for continuous system monitoring.
- Remote controlled functions of filter and condition monitoring.



## ***iprotect***<sup>®</sup> **Our energy**

### **Saving energy comes in many forms**

- *iprotect*<sup>®</sup> filter housings have optimized flow paths to minimize energy consumption.
- *iprotect*<sup>®</sup> filter elements apply an optional outer core with unique perforation pattern, optimizing flow distribution across the filter element.
- Low initial pressure loss across the filter element reduces energy consumption.
- Pressure loss across the filter element is optimized during its lifetime.
- Unique pleat technology optimize the flow distribution of the hydraulic fluid through the filter media.

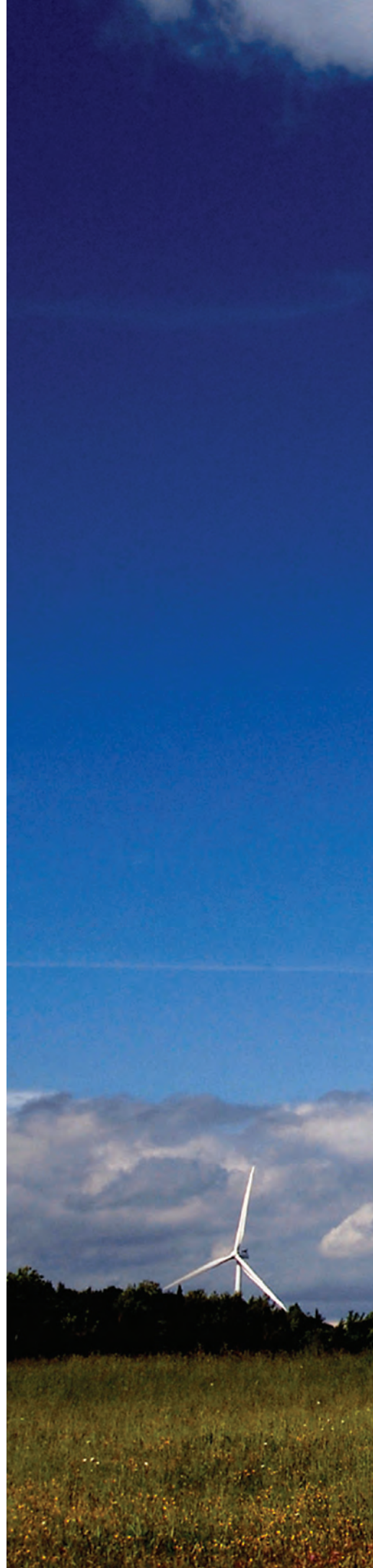

# ENERGY

Every *iprotect*<sup>®</sup> product applies the latest technology to contribute to help minimize the energy consumption across the filter. This reduces the cost of ownership and improves system efficiency and response times.



# LIFETIME

The image shows a large industrial machine, likely a water filtration system, in a factory setting. The machine consists of several large, white cylindrical components arranged in a row, mounted on a blue structural frame. The background shows a complex network of pipes and overhead structures, with a green beam labeled 'SWL 2 T' visible. The overall scene is brightly lit, highlighting the metallic and plastic surfaces of the equipment.

The market calls for lower cost of ownership against higher levels of productivity. Quality filtration is essential to achieve these goals, not only today but also in the future. The *iprotect*® product line avoids the use of pirate type alternative filters, acting as protective DNA gene securing the lifetime of the system and the fluid.

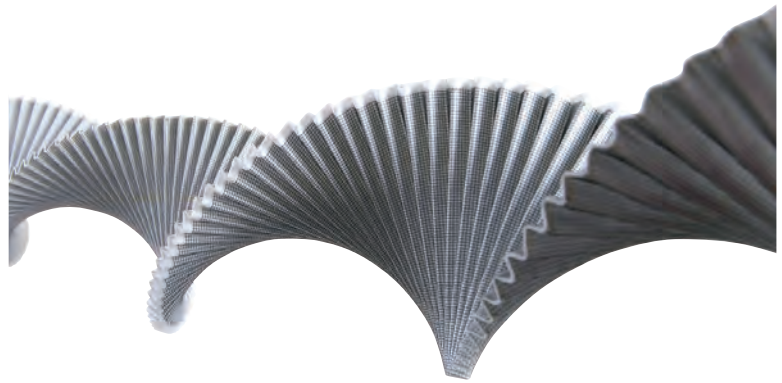

## ***iprotect*<sup>®</sup>** **System lifetime**

### **Extend system and fluid lifetime**

- Patented *iprotect*<sup>®</sup> filters extend the lifetime of components as the quality of filtration is safeguarded.
- Standard and customized filter media grades for dedicated conditioning of the oil.
- Improved filtration efficiency lowers the wear and tear process at comparable element lifetime.
- Zero-leakage bypass.



# ***iprotect***<sup>®</sup> **Your Performance**

## Patented *iprotect*<sup>®</sup> filter elements

- *iprotect*<sup>®</sup> filters housings have optimized flow path to minimize energy consumption.
- *iprotect*<sup>®</sup> filter elements apply an optional outer core with unique perforation pattern, optimizing flow distribution across the filter element.
- Low initial pressure loss across filter element reduces energy consumption.
- Pressure loss across filter element optimized during lifetime.



# PERFORMANCE

A large excavator is shown in a dimly lit tunnel, its arm extended towards a wall of earth and rock. The scene is illuminated by several bright, focused lights, creating a high-contrast environment. A worker wearing a hard hat is visible in the excavator's cab on the left. The tunnel walls are reinforced with metal mesh and wooden supports. The overall atmosphere is industrial and focused on heavy construction work.

With equipment operating often in public or hazardous areas, higher levels of control, safety and reliability are needed. Parker *iprotect*<sup>®</sup> products fulfil a vital role to gain maximum performance from hydraulic systems.



# IMAGE

Parker has recognized the importance of building OEM brand equity. Patented solutions ensure users of systems are consulting the OEM's network of spare parts for genuine parts. The *iprotect*<sup>®</sup> products provide customized branding opportunities to strengthen the OEM brand.



## ***iprotect***<sup>®</sup> **Your Image**

### **Quality serviceability**

- Genuine OEM parts available on global basis.
- High quality print for customizing OEM genuine parts, improving look of element and brand equity.
- Easy change of filter element, no risk of making mistakes.
- Reducing service time by 50% for filters supports lower cost of ownership.
- Customized filter element life time to meet specific OEM service intervals.
- Keep performance and reliability of equipment at a high level by using patented *iprotect*<sup>®</sup> filter elements.
- Extended warranty provision when using *iprotect*<sup>®</sup> products for Parker system components.



# ***iprotect***<sup>®</sup> **Our Environment**

## **Reduced environmental impact**

- Maximum use of reusable components like element core and bypass valve.
- Only the contaminated element pleatpack requires replacement.
- Over 50% lower disposal cost for end users.
- Easy change of filter element reducing oil leakage over 40%.
- Disposable parts can be fully incinerated *iprotect*<sup>®</sup> supports ISO14001.



# ENVIRONMENT

The world around us is changing. With a minimum investment the impact for our environment can be reduced. Parker's *iprotect*<sup>®</sup> products apply maximum use of reusable parts. Because the filter element remains in the bowl during change of filter element, oil leakage is reduced typically by over 40%.



# PROFIT

With over 60 years experience in filtration, Parker provides dedicated solutions to protect the profitability and productivity of hydraulic equipment. Parker *iprotect*® products provide a protected element after market for OEM's and designated network of spare part dealers.





## ***iprotect*<sup>®</sup> Your Profit**

### **Protected aftermarket**

- Typically over 90% aftermarket coverage.
- Controlled after market channels for OEM's or users of dedicated private branded *iprotect*<sup>®</sup> products.
- Provide optimal system efficiency of equipment sold to the market as filtration quality is secured.
- Reduced warranty cost.
- Improves OEM brand equity.
- Retention management improves as OEM's remain in contact with end users representing additional business opportunities.



# ***iprotect***<sup>®</sup> **System Integration**

## **Enabling compact solutions**

- Bypass valve and element core as integral part of filter bowl.
- Only one cavity needed for manifold block to accommodate the *iprotect*<sup>®</sup> filter.
- Filter element remains in filter bowl during element change, less space needed to service the filter.
- Modular building block approach ensures low cost integration of *iprotect*<sup>®</sup> filters with valve islands, manifold blocks or pumps.
- Condition monitoring option being integrated in filter housing module.





# SYSTEM INTEGRATION

Next generation systems often require a different approach when it comes to achieving technical and commercial targets. Parker *iprotect*<sup>®</sup> products are designed for easy and low cost integration in manifold block type solutions.

# Information EPF *iprotect*<sup>®</sup> Family

## **EMDPF *iprotect*<sup>®</sup>**

The EMDPF Series utilizes the unique patented *iprotect*<sup>®</sup> element. This manually operated duplex range covers flow rates up to 320 l/min at 420 bar.

Parker seal technology ensures Leakage-free operation of the ball valve, enabling safe replacement of filter elements when the system is in operation.

Parker duplex filters are standard supplied as standard with integrated equalizing line.



## **EADPF *iprotect*<sup>®</sup>**

The EADPF Series utilizes the unique patented *iprotect*<sup>®</sup> element. This manually operated duplex range covers flow rates up to 320 l/min at 350 bar.

This filter is based on a patented Parker design, allowing complete automatic change-over of the duplex filter. The EADPF is ideal for applications where service engineers cannot directly operate the duplex filter, for example for remote or hazardous applications.



## **EPF *iprotect*<sup>®</sup>**

The Parker EPF *iprotect*<sup>®</sup> in-line filters are suitable for flow capacity up to 700 l/min at 450 bar working pressure. A wide variety of bypass settings, filter medias, indicators and filter heads represent a dedicated fit to your system.

More compact solutions are possible because the filter element remains inside the filter bowl during service events.



# Customized Solutions

The EPF *i*protect® can be combined with **Parker Hydraulic components**. Example no.1 shows a hydraulic charge valve combined with the EPF *i*protect® high pressure filter, enabling more compact and lower cost solutions for hydraulic brake systems.

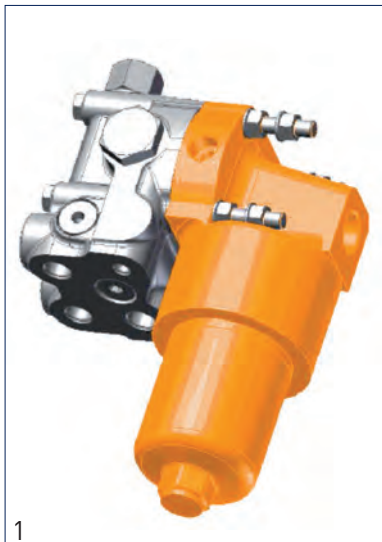

The EPF *i*protect® can be combined with **Parker Hydraulic valves**. Example no.2 shows a load sensing valve island with customized end plate module. The EPF *i*protect® high pressure filter is integrated into the valve and protects the pilot lines.

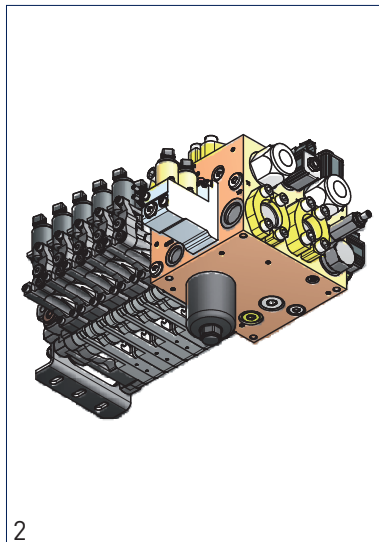

The EPF *i*protect® can be combined with **Parker manifold solutions**. Example no. 3 shows a manifold with integrated hydraulic valves and the EPF *i*protect® high pressure filter. Because the filter bypass is integrated into the bowl only one cavity is needed to accommodate the filter, This saves cost, space and reduces risk of leakage.

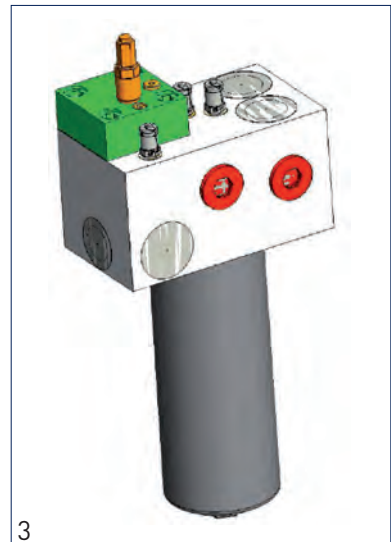

The EPF *i*protect® is ideal for system-matched solutions.

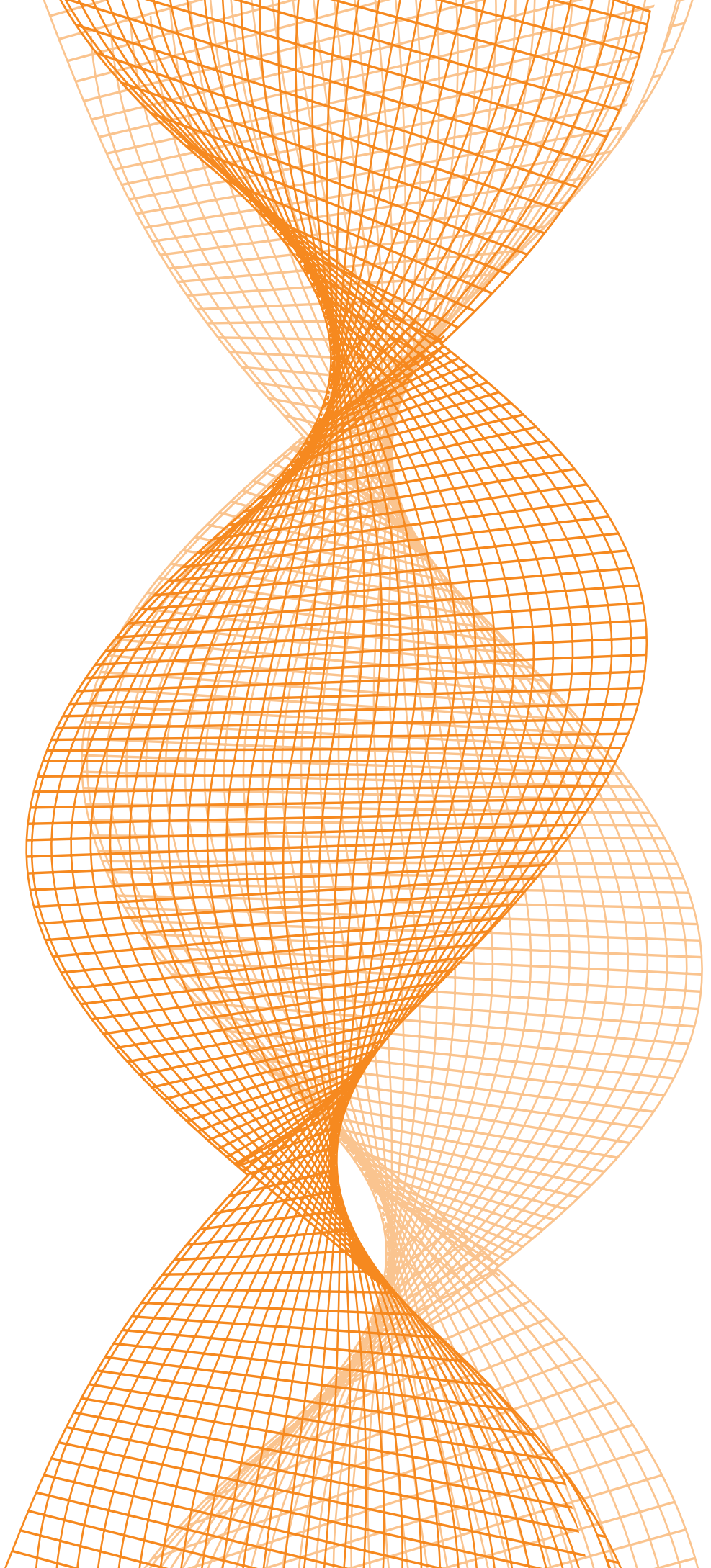

# Parker's Motion & Control Technologies

At Parker, we're guided by a relentless drive to help our customers become more productive and achieve higher levels of profitability by engineering the best systems for their requirements. It means looking at customer applications from many angles to find new ways to create value. Whatever the motion or control technology need, Parker has the experience, breadth of product and global reach to consistently deliver. No company knows more about motion and control technology than Parker. For further information call 00800 27 27 5374



## AEROSPACE

### Key Markets

- Aircraft engines
- Business & general aviation
- Commercial transports
- Land-based weapons systems
- Military aircraft
- Missiles & launch vehicles
- Regional transports
- Unmanned aerial vehicles

### Key Products

- Flight control systems & components
- Fluid conveyance systems
- Fluid metering delivery & atomization devices
- Fuel systems & components
- Hydraulic systems & components
- Inert nitrogen generating systems
- Pneumatic systems & components
- Wheels & brakes

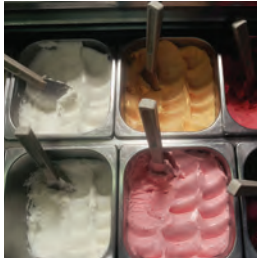

## CLIMATE CONTROL

### Key Markets

- Agriculture
- Air conditioning
- Food, beverage & dairy
- Life sciences & medical
- Precision cooling
- Processing
- Transportation

### Key Products

- CO<sub>2</sub> controls
- Electronic controllers
- Filter driers
- Hand shut-off valves
- Hose & fittings
- Pressure regulating valves
- Refrigerant distributors
- Safety relief valves
- Solenoid valves
- Thermostatic expansion valves

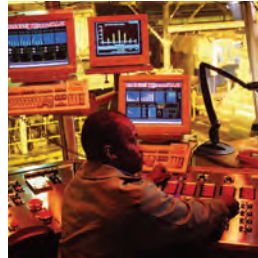

## ELECTROMECHANICAL

### Key Markets

- Aerospace
- Factory automation
- Life science & medical
- Machine tools
- Packaging machinery
- Paper machinery
- Plastics machinery & converting
- Primary metals
- Semiconductor & electronics
- Textile
- Wire & cable

### Key Products

- AC/DC drives & systems
- Electric actuators, gantry robots & slides
- Electrohydraulic actuation systems
- Electromechanical actuation systems
- Human machine interface
- Linear motors
- Stepper motors, servo motors, drives & controls
- Structural extrusions



## FILTRATION

### Key Markets

- Food & beverage
- Industrial machinery
- Life sciences
- Marine
- Mobile equipment
- Oil & gas
- Power generation
- Process
- Transportation

### Key Products

- Analytical gas generators
- Compressed air & gas filters
- Condition monitoring
- Engine air, fuel & oil filtration & systems
- Hydraulic, lubrication & coolant filters
- Process, chemical, water & microfiltration filters
- Nitrogen, hydrogen & zero air generators



## FLUID & GAS HANDLING

### Key Markets

- Aerospace
- Agriculture
- Bulk chemical handling
- Construction machinery
- Food & beverage
- Fuel & gas delivery
- Industrial machinery
- Mobile
- Oil & gas
- Transportation
- Welding

### Key Products

- Brass fittings & valves
- Diagnostic equipment
- Fluid conveyance systems
- Industrial hose
- PTFE & PFA hose, tubing & plastic fittings
- Rubber & thermoplastic hose & couplings
- Tube fittings & adapters
- Quick disconnects



## HYDRAULICS

### Key Markets

- Aerospace
- Aerial lift
- Agriculture
- Construction machinery
- Forestry
- Industrial machinery
- Mining
- Oil & gas
- Power generation & energy
- Truck hydraulics

### Key Products

- Diagnostic equipment
- Hydraulic cylinders & accumulators
- Hydraulic motors & pumps
- Hydraulic systems
- Hydraulic valves & controls
- Power take-offs
- Rubber & thermoplastic hose & couplings
- Tube fittings & adapters
- Quick disconnects

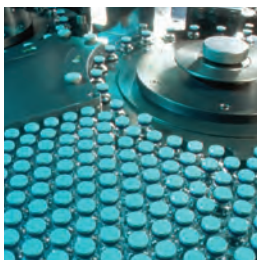

## PNEUMATICS

### Key Markets

- Aerospace
- Conveyor & material handling
- Factory automation
- Life science & medical
- Machine tools
- Packaging machinery
- Transportation & automotive

### Key Products

- Air preparation
- Brass fittings & valves
- Manifolds
- Pneumatic accessories
- Pneumatic actuators & grippers
- Pneumatic valves & controls
- Quick disconnects
- Rotary actuators
- Rubber & thermoplastic hose & couplings
- Structural extrusions
- Thermoplastic tubing & fittings
- Vacuum generators, cups & sensors



## PROCESS CONTROL

### Key Markets

- Chemical & refining
- Food, beverage & dairy
- Medical & dental
- Microelectronics
- Oil & gas
- Power generation

### Key Products

- Analytical sample conditioning products & systems
- Fluoropolymer chemical delivery fittings, valves & pumps
- High purity gas delivery fittings, valves & regulators
- Instrumentation fittings, valves & regulators
- Medium pressure fittings & valves
- Process control manifolds



## SEALING & SHIELDING

### Key Markets

- Aerospace
- Chemical processing
- Consumer
- Energy, oil & gas
- Fluid power
- General industrial
- Information technology
- Life sciences
- Military
- Semiconductor
- Telecommunications
- Transportation

### Key Products

- Dynamic seals
- Elastomeric o-rings
- EMI shielding
- Extruded & precision-cut, fabricated elastomeric seals
- Homogeneous & inserted elastomeric shapes
- High temperature metal seals
- Metal & plastic retained composite seals
- Thermal management



ENGINEERING YOUR SUCCESS.

# Parker Worldwide

**AE - UAE, Dubai**  
phone +971 4 8127100  
parker.me@parker.com

**AR - Argentina, Buenos Aires**  
phone +54 3327 44 4129

**AT - Austria, Wiener Neustadt**  
phone +43 (0)2622 23501-0  
parker.austria@parker.com

**AT - Eastern Europe, Wiener Neustadt**  
phone +43 (0)2622 23501 970  
parker.easteurope@parker.com

**AU - Australia, Castle Hill**  
phone +61 (0)2-9634 7777

**AZ - Azerbaijan, Baku**  
phone +994 50 2233 458  
parker.azerbaijan@parker.com

**BE/LU - Belgium, Nivelles**  
phone +32 (0)67 280 900  
parker.belgium@parker.com

**BR - Brazil, Cachoeirinha RS**  
phone +55 51 3470 9144

**BY - Belarus, Minsk**  
phone +375 17 209 9399  
parker.belarus@parker.com

**CA - Canada, Milton, Ontario**  
phone +1 905 693 3000

**CH - Switzerland, Etoy**  
phone +41 (0) 21 821 02 30  
parker.switzerland@parker.com

**CN - China, Shanghai**  
phone +86 21 5031 2525

**CZ - Czech Republic, Klecany**  
phone +420 284 083 111  
parker.czechrepublic@parker.com

**DE - Germany, Kaarst**  
phone +49 (0)2131 4016 0  
parker.germany@parker.com

**DK - Denmark, Ballerup**  
phone +45 43 56 04 00  
parker.denmark@parker.com

**ES - Spain, Madrid**  
phone +34 902 33 00 01  
parker.spain@parker.com

**FI - Finland, Vantaa**  
phone +358 (0)20 753 2500  
parker.fi nland@parker.com

**FR - France, Contamine s/Arve**  
phone +33 (0)4 50 25 80 25  
parker.france@parker.com

**GR - Greece, Athens**  
phone +30 210 933 6450  
parker.greece@parker.com

**HK - Hong Kong**  
phone +852 2428 8008

**HU - Hungary, Budapest**  
phone +36 1 220 4155  
parker.hungary@parker.com

**IE - Ireland, Dublin**  
phone +353 (0)1 466 6370  
parker.ireland@parker.com

**IN - India, Mumbai**  
phone +91 22 6513 7081-85

**IT - Italy, Corsico (MI)**  
phone +39 02 45 19 21  
parker.italy@parker.com

**JP - Japan, Tokyo**  
phone +(81) 3 6408 3901

**KR - South Korea, Seoul**  
phone +82 2 559 0400

**KZ - Kazakhstan, Almaty**  
phone +7 7272 505 800  
parker.easteurope@parker.com

**LV - Latvia, Riga**  
phone +371 6 745 2601  
parker.latvia@parker.com

**MX - Mexico, Apodaca**  
phone +52 81 8156 6000

**MY - Malaysia, Subang Jaya**  
phone +60 3 5638 1476

**NL - The Netherlands, Oldenzaal**  
phone +31 (0)541 585 000  
parker.nl@parker.com

**NO - Norway, Ski**  
phone +47 64 91 10 00  
parker.norway@parker.com

**NZ - New Zealand, Mt Wellington**  
phone +64 9 574 1744

**PL - Poland, Warsaw**  
phone +48 (0)22 573 24 00  
parker.poland@parker.com

**PT - Portugal, Leca da Palmeira**  
phone +351 22 999 7360  
parker.portugal@parker.com

**RO - Romania, Bucharest**  
phone +40 21 252 1382  
parker.romania@parker.com

**RU - Russia, Moscow**  
phone +7 495 645-2156  
parker.russia@parker.com

**SE - Sweden, Spånga**  
phone +46 (0)8 59 79 50 00  
parker.sweden@parker.com

**SG - Singapore**  
phone +65 6887 6300

**SK - Slovakia, Banská Bystrica**  
phone +421 484 162 252  
parker.slovakia@parker.com

**SL - Slovenia, Novo Mesto**  
phone +386 7 337 6650  
parker.slovenia@parker.com

**TH - Thailand, Bangkok**  
phone +662 717 8140

**TR - Turkey, Istanbul**  
phone +90 216 4997081  
parker.turkey@parker.com

**TW - Taiwan, Taipei**  
phone +886 2 2298 8987

**UA - Ukraine, Kiev**  
phone +380 44 494 2731  
parker.ukraine@parker.com

**UK - United Kingdom, Warwick**  
phone +44 (0)1926 317 878  
parker.uk@parker.com

**US - USA, Cleveland**  
phone +1 216 896 3000

**VE - Venezuela, Caracas**  
phone +58 212 238 5422

**ZA - South Africa, Kempton Park**  
phone +27 (0)11 961 0700  
parker.southafrica@parker.com

## Parker Hannifin

Free phone (EPIC): 00 800 27 27 5374

Email: [filtrationinfo@parker.com](mailto:filtrationinfo@parker.com)

[www.parker.com/hfde](http://www.parker.com/hfde)

[www.parkerhfde.com](http://www.parkerhfde.com)

